

The Beauty Shop



Finished size of quilt: 38" x 51"

Finished size of quilt: 41" x 56"

Quilt design and piecing by Laura Blanchard. Machine quilting by Valerie Schlake.



Fabric from the "The Beauty Shop" collection by Red Rooster Studio

FABRIC REQUIREMENTS FOR PASTEL QUILT

Pattern #16032 – RED1.....	1 yard
16033 – DKPIN1	2 yards
16034 – PIN1.....	¼ yard
16034 – BLU1.....	⅝ yard
16035 – YEL1	¼ yard
16035 – DKBLU1.....	1½ yards (includes ¾ yard for bias binding)
16037 – PIN1.....	⅓ yard
16039 – YEL1	1 yard (plus additional 2⅔ yards for backing)
Paper-backed fusible web.....	2½" x 6½"
Batting.....	47" x 66"

CUTTING INSTRUCTIONS *Cut fabrics in order given.*

A. Pattern #16032 RED1 (large master print):

1. Fussy-cut two 8½" wide x 6½" high motifs for Row 9, Windows #1 and #5.
2. Fussy-cut two 6½" square motifs for Row 9, Windows #2 and #4.
3. Fussy-cut one 6½" wide x 8½" high motif for Row 9, Window #3.

B. Pattern #16033 DKPIN1 (border stripe):

1. Cut one 7¼" x 42" strip each from the hair dryer motif row (for Row 2) and the cosmetic motif row (for Row 16).
2. Cut two 2" x 42" strips of the nail polish print for Rows 3 and 11.
3. Cut two 2" x 42" strips of the slipper print for Rows 7 and 15.
4. Cut two 2" x 42" strips of the dog and purse print for Rows 5 and 13.

C. Pattern #16034 PIN1 (stars on pink):

1. Cut one 6" x 42" strip. Crosscut into four 6" squares. Cut each square in half twice on the diagonal. Label "A" (Rows 6 and 12).

D. Pattern #16034 BLU1 (stars on blue):

1. Cut five 2" x 42" strips (Rows 4 and 14).
2. Cut three 1½" x 42" strips. Make four 18½" crosscuts and four 6½" crosscuts (Row 9 sashing).
3. Cut one 2½" x 42" strip. Make two 6½" crosscuts (Row 9 sashing).

E. Pattern #16035 YEL1 (yellow texture):

1. Cut two 1½" x 42" strips (Rows 8 and 10).

F. Pattern #16035 DKBLU1 (blue texture):

1. Cut one 2¾" x 42" strip (Row 1).
2. Cut four 2" x 42" strips (Rows 4 and 14).
3. Cut four 1" x 42" strips for flat-fold piping (Row 9).
4. Cut one 5" x 42" strip (Row 17).
5. Cut as many 2½" bias strips as needed to equal 240" for binding.
6. Reserve one 3" x 7" rectangle from leftover blue texture fabric for applique in center of Rows 8 and 10.

G. Pattern #16037 PIN1 (light pink print):

1. Cut one 6" x 42" strip. Crosscut into four 6" squares. Cut each square in half twice on the diagonal. Label "B" (Rows 6 and 12).
2. Cut one 3" x 42" strip. Crosscut four 3" x 5" rectangles for Rows 6 and 12. Cut a 45° angle at one end of two rectangles ("C"). Cut a 45° angle at the opposite end of the two remaining rectangles ("D") (Figure 1).



Figure 1

H. Pattern #16039 YEL1 (yellow lingerie print):

1. Fussy-cut twelve 5" squares from 1 yard of the lingerie print (Rows 4 and 14).

PIECING INSTRUCTIONS

A. Rows 4 and 14:

1. Sew two 2" x 42" blue star strips to one 2" x 42" blue texture strip (Figure 2). Press toward the blue texture strip. Make two.



Figure 2

2. Crosscut a total of thirty-four 2" units (Figure 3).

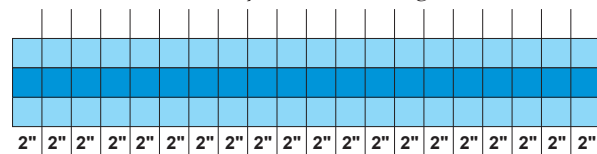

Figure 3

3. Sew one 2" x 42" blue star strip to one 2" x 42" blue texture strip (Figure 4). Press toward the blue texture.



Figure 4

4. Crosscut twenty 2" units. Sew five units together as shown in Figure 5. Press top and bottom seams in direction of arrows. Make four.

5. Crosscut twenty 2" squares from the remaining 2" x 42" blue texture strip.
6. Arrange the checkerboard units from Steps 2 and 4, the 2" blue squares and the 5" yellow lingerie print squares, to make Rows 4 and 14 (Figure 6). Sew units together. Press seams toward the 2" blue squares and the 5" yellow squares for each row.

Figure 5

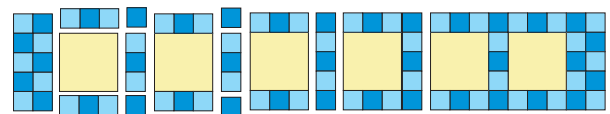

Figure 6

B. Rows 6 and 12:

1. Draw ¼" seam allowances on the wrong side of "A", "B", "C" and "D". Sew seven "B" triangles to eight "A" triangles, matching intersections (Figure 7). Press seams in one direction. Sew "C" and "D" to opposite ends of the row, matching intersections. Press to "C" and "D". Make two (Rows 6 and 12).



Figure 7

C. Row 9: Arrange the blocks for Windows #1-5 so that the images are upright.

1. Flat-fold piping:
 - a. Press the four 1" x 42" blue texture strips in half lengthwise, wrong sides together.
 - b. Cut the pressed strips into fourteen 6½" lengths and six 8½" lengths.
 - c. Baste or glue-baste the flat-fold piping strips to the edges of the motif blocks for Windows #1-5, raw edges even.
2. Sashing:
 - a. Sew a 1½" x 6½" sashing strip to opposite sides of the 6½" squares for Windows #2 and #4 (Figure 8) sewing through the sashing strip, flat-fold piping and the square. Press toward sashings.

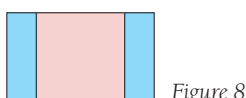

Figure 8

- b. Sew a 2½" x 6½" sashing strip to the left side of Window #1 and to the right side of Window #5. Join Windows #1 and #2. Press. Sew the 1½" x 18½" sashing strips to the top and bottom of the unit. Press toward sashing strips. Repeat with Windows #4 and #5. Add Window #3 in the center to complete the row. Press toward sashings.

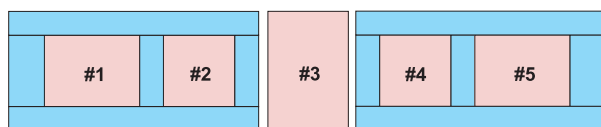

Figure 9

D. Rows 8 and 10:

1. Trace the applique shape (including the curved line) onto the paper side of paper-backed fusible web. Press to the wrong side of the 3" x 7" blue texture strip. Cut out on the straight and curved lines, releasing two shapes. Remove the paper backing.
2. Find the center of the two 1½" x 42" yellow strips for Rows 8 and 10. Match the centers of the yellow strips with the centers of the applique pieces. Press the appliques to the right side of each yellow strip, straight edges even. Machine applique using the stitch of your choice.

QUILT ASSEMBLY

1. Arrange rows in numerical order (refer to quilt photo and diagram).
2. Sew Rows 8 and 10 to Row 9, centering appliques on Window #3 (refer to photo for position). Press toward Row 9.
3. Join the remaining rows, matching centers, then add to Rows 8-10. Press all seams to narrow rows. (Rows will not be the same length.)

FINISHING

A. Preparing to quilt:

1. Square up edges of quilt so that all rows are even with Rows 4 and 14.
2. Prepare the backing with a horizontal seam to measure 47" x 66".
3. Layer quilt top, batting and backing.

4. Baste layers together. Quilt as desired.
5. After quilting is completed, trim batting and backing even with quilt top.

B. Marking the wavy edge:

1. With a chalk marker, draw a freehand wavy edge at the top of Row 1 and the bottom of Row 15. When the drawn line is just as you want it, cut with scissors on the line through all three layers of the quilt.

[Tip: To draw a freehand wavy edge, cut a piece of paper the length of the edge to be shaped - this may require taping a few sheets of paper together to obtain the correct length. Fold the paper in half, end to end. With the paper folded, use a pencil to draw the desired shape from the short, cut edge of the paper to the fold. Adjust the drawing if needed. Staple the layers of paper in a couple of places along the edge. Cut the wave with scissors. Remove the staples, unfold the paper and pin to the quilt. Use a chalk marker to mark the wave on the fabric.]

C. Binding:

1. Join the bias binding strips with diagonal seams. Press seams open.
2. Sew binding to quilt, beginning and ending on a long side. Be careful not to stretch the binding as you sew on the curves.
3. Attach a hanging sleeve, if desired, and don't forget a label.

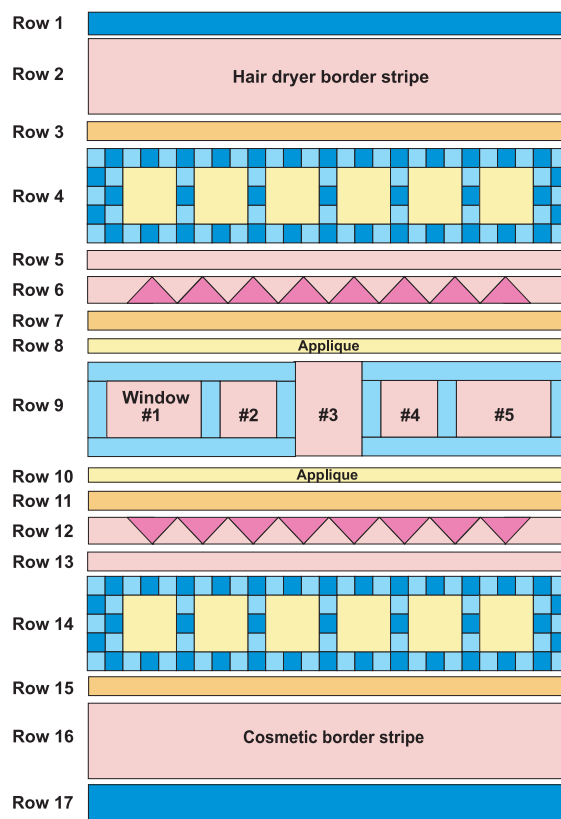

Applique shape 100%

